



955

STAGE V
POWERFUL
FAST AND DURABLE
ALL YEAR ROUND



www.greenmachines.com
+389 43 551 100
office@greenmachines.com



WELCOME TO THE WORLD OF GREEN MACHINES

WHERE INNOVATION BEATS IMITATION

Green Machines is among the oldest manufacturers of sweepers, dating back to 1965 and our first headquarters in Scotland. From the very first walk-behind sweepers with their exceptional maneuverability to state-of-the-art battery and hydrogen technology present in our sweepers, Green Machines has created a market which remains unrivaled to date. We currently operate from our offices in North Macedonia, the Netherlands, United Kingdom and USA, while we offer clients all around the world full support through our wide global dealership network. With our ambitious Green Machines vision, we plan to stay ahead of the game by bringing new product technologies to the highly demanding outdoor cleaning market. For many years now, we have aimed to contribute decisively towards cleaner and tidier towns and cities by providing efficient and sophisticated sweeping machines. Our portfolio comprises 8 machines models and each one is unique in its own way. We offer you a wide range of choices by providing cleaning solutions that others have yet to catch up to. All of our machines are compact and swift enough to enable you to clean any urban area around the city with maximum efficiency, without worrying that they will disrupt your citizens. Our machines are purposefully designed in a way that does not impact the normal everyday functioning even of the busiest areas in your city.





OUR MISSION: ZERO EMISSIONS

Green Machines realizes that the earth's environment is under severe stress from uncontrolled human activity, threatening the survival of our society and the performance of Green Machines' mission. We are dedicated to minimizing our own impact and maximizing the effective use of resources. Green Machines strives to develop and produce sustainable sweeping machines combined with excellent performance for a better world. Our vision is often far from the traditional approach but we are proud to take leadership in paving the path to an emissionfree world. Our vision focuses on minimizing global impact through the following guidelines:

- Help our customers reduce their carbon footprint through the use of our eco-friendly products.
- Maximize the "End of Life Environmental Value" of our products.
- Work with suppliers who promote sustainable practices.
- Participate in efforts to further improve sustainable protection and understanding among our staff and end-users across the globe.
- Listen to the voice of the customers.

KEEPS YOUR CITY CLEAN AND GREEN



PORTFOLIO

We have over 60 years of manufacturing experience and we are constantly improving our products based on direct customer feedback and the ongoing changes and trends on the market. Our current product portfolio comprises some of the world's most technologically advanced sweepers, and each of our machines is so unique that it is basically impossible to compare them to one another. Every machine is designed in a way that meets specific needs and we are confident that we have a machine that will meet your specific needs.



GM1ze

Fully electric, versatile, waste Vacuum Cleaner. Small manoeuvrable and Compact, ideal for any City Centre.



GM400ze/GM414

One of our latest environmental sweeper innovations, the 400ze is based on the world beating 400-series Sweeper. Compact, manoeuvrable, Operator friendly and now also Electric.



GM500ze

The 500ze is the world's first fully electric sweeper, delivering long-lasting performance with advanced Li-ion batteries. Compact, swift, and eco-friendly, it features a superb ergonomic design and is one of the most popular zero-emission sweepers worldwide.



GM500H2

The world's first-ever hydrogen fuel cell sweeper. It runs 100% on hydrogen with zero emissions, while providing the same comfort and cleaning efficiency the 500ze offers. It comes in two types: with replaceable H2 pods or with a fixed hydrogen tank system.



GM636HS

Our dependable, hard working front line sweeper will remove debris from all surfaces and efficiently, it has a 1.5m³ capacity, designed for maximum performance and minimum waste volume. With its sophisticated design details and ability to considerably reduce water consumption, the 636 cuts labor and maintenance costs.



GM720ze

Engineered for efficiency and versatility, with a 2m³ hopper and 4-wheel steering for excellent maneuverability. Its advanced design maximizes debris collection - ideal for demanding tasks.



GM955

The 955 is a 6m³ mechanical sweeper supported by vacuum. The powerful sweeping mechanism is able to collect even the largest debris, the powerful Vacuum will remove the smallest dust particles with the 955 you have the best of two worlds.

GM955

First 6 m³ mechanical sweeper supported by vacuum.



The GM 955 is a 6 m³ mechanical sweeper supported by vacuum that combines the best of both worlds. This combined collection system is based on brushes conveying the dirt towards the cleaning path in the central area of the machine. The central cylindrical brush loads it on a mechanical elevator by rotating it in the opposite direction of the sweeper's movement. The dirt is then unloaded inside the waste container. The total dust suppression is obtained through the combination of the abovementioned system with the depression inside the container, generated by a powerful suction fan. This action ensures maximum cleaning effect on the sweeper's cleaning path. A series of filters located inside the waste container filter the air before releasing it in the atmosphere. This system allows the collection of bulky material at high sweeping speed as well, unlike the vacuum sweepers based on suction system only. The use of water on the brush is minimized or eliminated completely.

955 Technical Specifications

Dimensions

Length- standard machine	5.397 mm
Length- standard machine with third brush	6.912 mm
Width- without side brushes	2.070 mm
Width - with brushes	2.430 mm
Max. height	3.100 mm

Performance

Cleaning path width

- with main brush	1.320 mm
- with main brush + right and left side brushes	2.700 mm
- with main brush + right and left side brushes + front 3rd brushes	3.600 mm

Diameter of the brushes

- side brushes	1.000 mm
- main brush	650 x 1.320 mm
- front brush	1.300 mm

Vacuum system	560 mm fan with 8.500 m ³ air/h
Sweeping speed	0-20 km/h
Transferring speed	0-40 km/h

Mass/ capacity/ weights

Gross vehicle weight	13.700 kg
Fuel tank capacity	120 L

Accessories and upgrades:



Rear-view camera



Flexible suction hose



Air conditioning with pollen filter



Sound-proofed cabin



Ergonomic and adjustable seats



Large, curved windscreen for full visibility

Operator cabin

Frame	Steel bearing structure
Number of seats	2
Drive	Right side (left upon request)
Air conditioning	Automatic with pressurization

Waste container

Waste container volumetric capacity	6m ³
Material	Stainless steel
Dumping height	1.150mm

Engine

Brand	Mercedes
Model	OM934LA.E5-3
Number of cylinders	4
Effective engine capacity	5.132 cc
Maximum power	129 Kw (176 Hp) at 2200 rpm
Cooling	Water cooling
Type	Turbocharger diesel
Emission acc. to:	EU Stage V

Brakes/ Suspension/ Steering

Service and emergency brakes	Dry disc brakes
Parking brake	Dry disc – type mechanical parking brake on the transmission
Front suspension	Parabolic leaf springs and hydraulic shock absorbers
Rear suspension	Hydraulic
Steering	Power assisted hydraulic steering
Steering axle	Independent front and rear axle power steering
Wheels dimensions	295/60 R 22,5 road type tyres



SWEeper FEATURES



Dashboard

New modern dashboard panel with electronic interface based in the lower part of the steering wheel console. The display has an excellent information preview in both day and night working conditions.



Control panel

The sweeper controls are gathered on a single console panel featuring simple and user-friendly buttons for each function.



Rear-view camera

The camera has a 7" LED -display with a digital backlit screen that increases the image's contrast. It has been designed to resist the strongest mechanical shocks and it allows to monitor both the sweeper operations in reverse gear and the side brush movements.



Normal tipping / High dump

With the high dump option, dumping height ranges from 1150 mm to 2300 mm. It enables unloading into any location or garbage container.



Mercedes-Benz engine

The sweeper is equipped with a Mercedes-Benz 4-cylinder turbo diesel engine. This is a low emission water-cooled engine complying with local regulations and combines fuel efficiency, high power output and low noise. The quality of the engine is backed by its worldwide service network.



Third brush

The construction and long reach of the optional 3rd brush, both left and right, enable it to reach the areas which are most difficult to sweep.



Side brushes

By working in the opposite direction from the sweeper's forward movement, they provide optimal cleaning of difficult surfaces. The operator can adjust the pneumatic pressure from the cabin, as well as set the brush's rotation speed, thus reducing the maintenance cost.



New generation CPC4-Ecan Control Unit

The GM 955 comes with the latest generation of the CPC4-Ecan control unit built in. The CPC4 control unit combined with the MCM2 electronic engine control unit constantly monitors the engine and carries out required self-diagnostics.

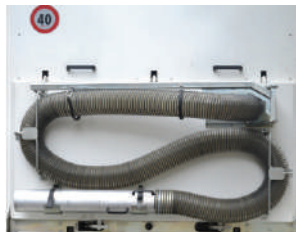

Suction hose

A powerful and easy to use suction hose which collects litter, large amounts of leaves, etc. It is over 5 m long and it has been designed to clean hard-to-reach places and even heavily polluted areas such as culverts and storm drains in which litter tends to build up.

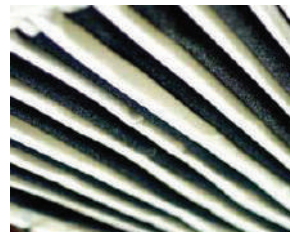

Special PM10 antipollution filter

Made of special microstructure fabric that collects the smallest dust particles, while allowing air to pass unobstructed through the filter membrane. This unique feature extends the filter's lifespan considerably and reduces maintenance cost without any efficiency loss.

GM955



Vacuum that reduces PM10 dust emissions by up to 99% compared to air sweepers.

It can be used anywhere in the world - from hot, dry and dusty to freezing weather conditions.

Independent 4-wheel steering with large 22.5" wheels.

Fitted with an industrial 129 kW Mercedes Benz Engine.

Large 24 m² container filter with shaker (PM2.5)



Hydraulic height adjustment enabling to raise the machine's height to avoid obstructions such as road humps.

The tilting cabin is suspended by shock absorbers granting swift access to the engine and hydraulic systems so maintenance can be performed with ease and high efficiency, saving time and money.

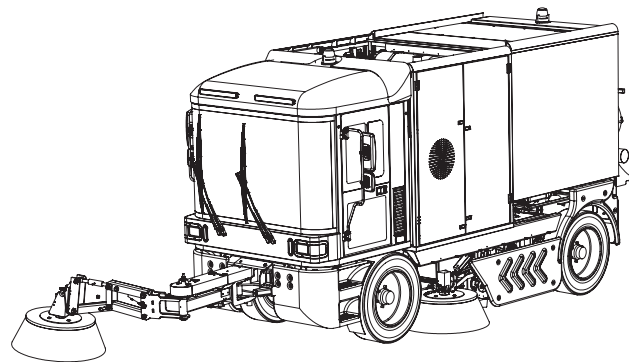
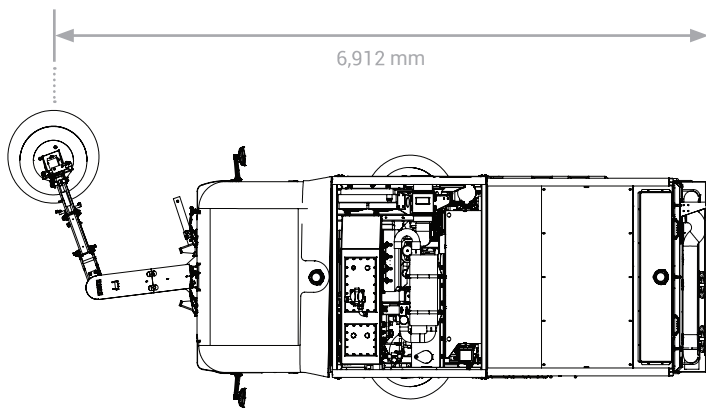
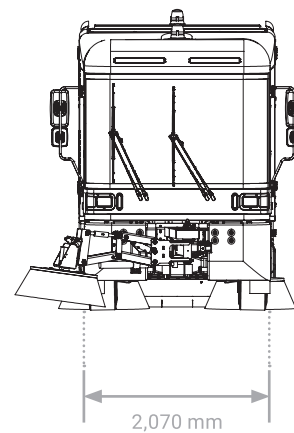
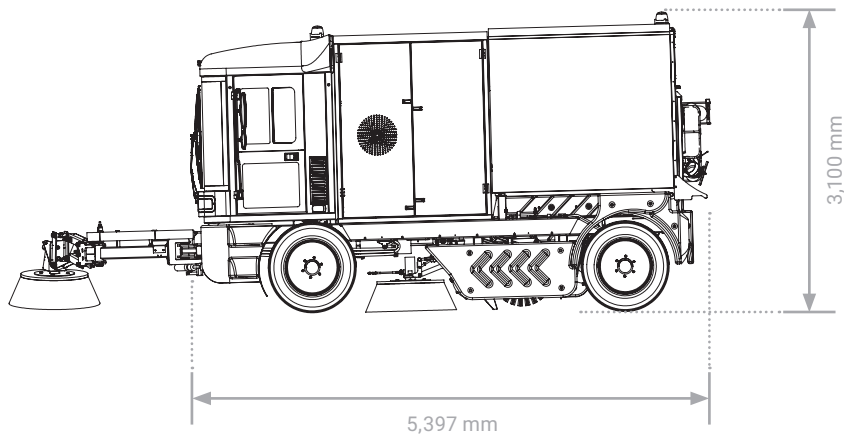



Green Machines International B.V.
The Netherlands
+389 43 551 100
office@greenmachines.com

Green Machines Veles DOO
North Macedonia
+389 43 551 100
office@greenmachines.com

Green Machines Inc.
5644 Kearny Mesa Rd, Unit B
92111 San Diego, CA, USA
T: +1 877 817 0342
T: +1 619 780 6772
F: +1 626 884 5164

GM Sweepers UK Ltd.
United Kingdom
Sales: +44 (0) 1324 611666
Spares: +44(0)1324 578880
sales@greenmachines.com
spares@greenmachines.com